

Vögelebichl mutli-family houses, Innsbruck

The buildings are pioneers in new energy standards. Furthermore, they were designed to achieve the annual net-zero energy balance thanks to on-site renewable energy generation. In addition to the heat pump, solar energy is used to power the two blocks.

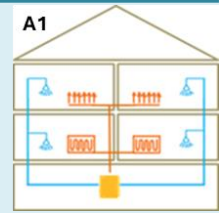

Key facts for the heat pumps (not including solar energy)

Buildings

Location	Innsbruck, Austria
Construction	2015
Heat distribution	underfloor heating
No. of apartments	26 flats
Heated area	2149 m ²

Heat pump and source

Number of	1
Installed power	B0/W35 44kW
Operation mode	monoenergetic
Heat source	groundwater

Heating system

Heat demand	17,9/(m ² a)
Heating temperature	35 / 55°C

Domestic hot water

Type of system	central
Heat demand	26 kWh/(m ² a)

Other information

Air renewal	Ventilation system
Solar installation	North block PV&ST South block PV
COP	4.7

Lessons learned

- Vögelebichl was designed as a net-zero energy building (NZEB), thus, to achieve the annual net-zero energy balance thanks to on-site renewable energy generation. Although the balance has not been achieved in the monitored years, simulations showed the possibility to achieve it.
- However, the net-zero balance would be obtained thanks to the large PV yield surplus during summer, which might be a problem for the grid stability and it is not so effective in reducing the building specific CO₂ emissions. Therefore, the net-zero balance on an annual basis might be a misleading approach to ensure low CO₂ emissions.



Vögelebichl multi-family houses were built in Innsbruck in 2015 by the local social housing company, Neue Heimat Tirol (NHT). One heating central connects the two building blocks: the north (N) block has four floors and hosts sixteen flats; the south (S) block is just three floors high and hosts ten flats. It complies with the Passivhaus Plus certification, which, in addition to limiting the annual heating energy demand to 15 kWh/(m²a), requires the building to have a bounded renewable primary energy demand of maximum 45 kWh/(m²a) and to generate a minimum amount of renewable energy on-site (60 kWh/(m²a)). The building was not merely designed to meet the highest energy performance requirements, but also to maximize the nonrenewable primary energy saving by balancing the energy demand for heating, DHW, and ventilation with the on-site renewable energy, hence targeting to achieve yearly net-zero energy balance. The facility is monitored by the Unit of Energy Efficient Building of the University of Innsbruck since the beginning of operation.

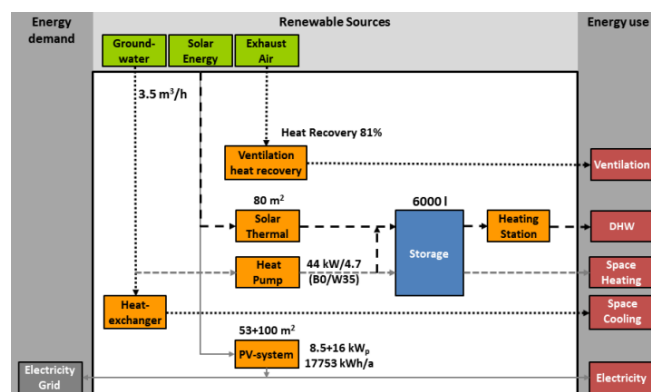

Vögelebichl mutli-family houses, Innsbruck

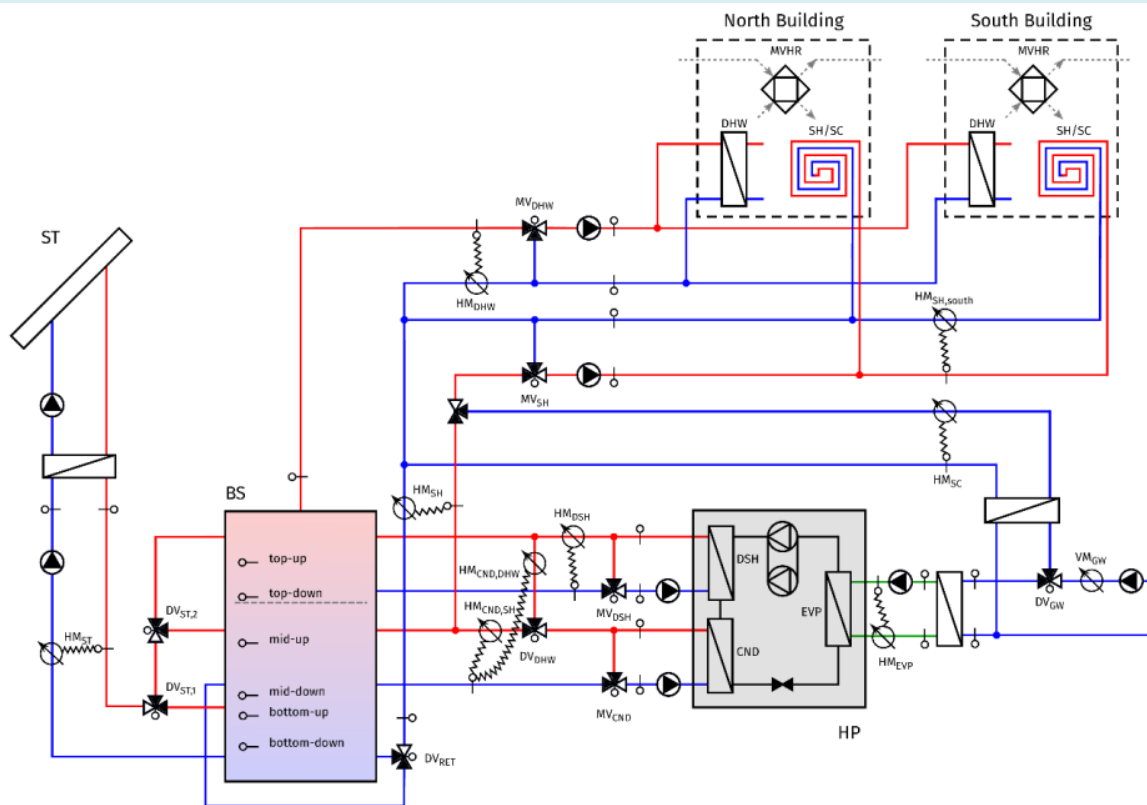

HVAC system schematic with monitoring system

Description of the technical concept

The building's HVAC system consists of two parts: the hydronic system and the ventilation system. The ventilation units ensure hygienic air renewal, whereas the hydronic system provides low temperature space heating (SH) and DHW preparation with decentral fresh water heat exchangers connected to a central heat pump (HP) and solar thermal (ST) collectors. The HP is double-staged – allowing it to work at two levels of power – and provided with an additional heat exchanger, i.e. the de-superheater (DSH). The purpose of the DSH is to deliver heat at a high temperature level (e.g. heat for DHW) while not raising the condensation temperature (simultaneously delivering SH), thus at higher energy performance. Heated system-water is stored in a combi-storage tank from which it is withdrawn for SH and DHW preparation. If stratification is properly ensured, combi-storages offer the possibility to save costs and reduce storage losses.

The advantage of storing system-water rather than hot drinking-water, which is prepared in the flats by decentralized DHW heat-exchangers, reduces the temperature at which the water must be heated to avoid Legionella growth, allowing for better HP performance and thus energy savings. The south building (S) roof is completely covered by PV, while the north building (N) is covered partly by ST and partly by PV panels to ensure the on-site electricity generation for achieving the net-zero energy balance.

Photos: IEA HPT Annex 49 “Vögelebichl Multi-Family Passive Houses”